



## LIMITED WARRANTY

NILES AUDIO CORPORATION ("NILES") WARRANTS ITS ACTIVE PRODUCTS (THOSE NOT REQUIRING AC OR BATTERY POWER) TO THE ORIGINAL PURCHASER TO BE FREE OF MANUFACTURING DEFECTS IN MATERIAL AND WORKMANSHIP FOR A PERIOD OF TWO YEARS FROM DATE OF PURCHASE.

THIS WARRANTY IS SUBJECT TO THE FOLLOWING ADDITIONAL CONDITIONS AND LIMITATIONS. THE WARRANTY IS VOID AND INAPPLICABLE IF NILES DEEMS THAT THE PRODUCT HAS BEEN USED OR HANDLED OTHER THAN IN ACCORDANCE WITH THE INSTRUCTIONS PROVIDED BY THE MANUFACTURER, INCLUDING BUT NOT LIMITED TO DAMAGE CAUSED BY ACCIDENT, MISHANDLING, IMPROPER INSTALLATION, ABUSE, NEGLIGENCE, OR NORMAL WEAR AND TEAR, OR ANY DEFECT CAUSED BY REPAIR TO THE PRODUCT BY ANYONE OTHER THAN NILES OR AN AUTHORIZED NILES DEALER.

TO OBTAIN WARRANTY SERVICE, TAKE THE UNIT TO THE NEAREST AUTHORIZED NILES DEALER, WHO WILL TEST THE PRODUCT AND IF NECESSARY, FORWARD IT TO NILES FOR SERVICE. IF THERE ARE NO AUTHORIZED NILES DEALERS IN YOUR AREA, YOU MUST WRITE TO NILES AND INCLUDE YOUR NAME, MODEL AND SERIAL NUMBER OF YOUR UNIT, ALONG WITH A BRIEF DESCRIPTION OF THE PROBLEM. A FACTORY RETURN AUTHORIZATION NUMBER WILL BE SENT TO YOU. DO NOT RETURN ANY UNIT WITHOUT FIRST RECEIVING WRITTEN AUTHORIZATION AND SHIPPING INSTRUCTIONS FROM NILES.

IF THE ABOVE CONDITIONS ARE MET, THE PURCHASER'S SOLE REMEDY SHALL BE TO RETURN THE PRODUCT TO NILES, IN WHICH CASE NILES WILL REPAIR OR REPLACE, AT ITS SOLE OPTION, THE DEFECTIVE PRODUCT WITHOUT CHARGE FOR PARTS OR LABOR. NILES WILL RETURN A UNIT REPAIRED OR REPLACED UNDER WARRANTY BY SHIPPING SAME BY ITS USUAL SHIPPING METHOD FROM THE FACTORY (ONLY) AT ITS EXPENSE WITHIN THE UNITED STATES OF AMERICA. THERE ARE NO OTHER WARRANTIES, INCLUDING WITHOUT LIMITATION, EITHER EXPRESS OR IMPLIED WARRANTIES OF MERCHANTABILITY OR FITNESS FOR A PARTICULAR PURPOSE, WITH RESPECT TO THE PRODUCT.

REPAIR OR REPLACEMENT AS PROVIDED UNDER THIS WARRANTY IS THE EXCLUSIVE REMEDY OF THE CONSUMER/PURCHASER. NILES SHALL NOT BE RESPONSIBLE FOR ANY INCIDENTAL OR CONSEQUENTIAL DAMAGES EXCEPT TO THE EXTENT PROVIDED (OR PROHIBITED) BY APPLICABLE LAW. SOME STATES DO NOT ALLOW THE EXCLUSION OR LIMITATION OF INCIDENTAL OR CONSEQUENTIAL DAMAGES, SO THE ABOVE LIMITATION MAY NOT APPLY TO YOU. THIS WARRANTY GIVES YOU SPECIFIC LEGAL RIGHTS, AND YOU MAY ALSO HAVE OTHER RIGHTS WHICH VARY FROM STATE TO STATE.

FOR THE NAME OF YOUR NEAREST AUTHORIZED NILES DEALER CONTACT: NILES AUDIO CORPORATION, P.O. BOX 160818, MIAMI, FLORIDA 33116-0818.

Please fill in your product information and retain for your records.

Model MS120 Purchase Date \_\_\_\_\_  
Serial No. \_\_\_\_\_

## SPECIFICATIONS

### IR System

Compatible with virtually all brands of remotes using carrier frequencies between 25kHz and 90kHz

### IR Receiving Range

Varies depending on remote strength; typically 20' to 35' (6.10 meters to 10.68 meters)

### IR Receiving Angle

30° off-axis (horizontal and vertical) at 25' (7.62 meters)

### Mounting

Thru-hole, fits into a 1/2" (1.27 cm) diameter hole; requires a minimum of 2-7/8" (7.31 cm) mounting depth

### Wiring Requirements

Individual home-run of CAT-5 cable

### Unit Dimensions

Front Bezel:  
3/4" (1.91 cm) diameter x 1/4" (.64 cm) high

Overall Unit:  
1/2" (1.27 cm) diameter x 2-7/8" (7.31 cm) long

### Contents

MS120 Sensor x 1

Washer x 1

Hex Nut x 1

Black and White Bezel

The conditions which sometimes combine to create a feedback loop are:

1. Both a sensor and a flasher are located within the same room.
2. There is some low-level noise or interference on your system.

You can eliminate optical feedback by replacing any IRB1 "flooding flasher" with an MF1 or MF2 MicroFlasher® and covering all flashers with the supplied IR blocking covers.

### EMI (Electromagnetic Interference)

Identify the source of the interference. The most common sources of electromagnetic interference are listed in the Installation Considerations section. To eliminate EMI try the following methods:

1. Move the sensor or the sensor cable away from the EMI source or move the source of the EMI away from the sensor or the cable.
2. Connect the Sensor's GND terminal to true earth ground (if this isn't feasible use the main system unit's GND terminal).

There are many methods for reducing interference. Which solution is best for you depends on your situation. If you require further assistance call Niles Technical Support at 305-238-4373 or 1-800-289-4434 (M-F 8:00 AM - 7:00PM ET).

You can also email Niles Technical Support at support@nilesaudio.com.

## TROUBLESHOOTING

This manual contains instructions for the MS120 only. For specific information on the adjustment and operation of your Niles infrared extender system, please refer to the instruction manual included with your Niles IR main system unit (MSU140, MSU250, MSU480 MSU440Z).

1. Test the remote control(s) by operating the A/V equipment directly. Replace the batteries if needed.
2. Double check the cable connections on the MS120 and on the main system unit. Look for open, shorted or reversed wires.
3. Test for interference from the following sources:
  - Neon, Compact Florescent Lighting (CFL), or halogen lights in the room
  - Light dimmers, beginning with those closest to the MS120

Observe the main system unit IR confirmation LED while performing all the tests. It is possible to have interference from more than one source.

### Eliminating Optical Feedback

In some installations, two conditions combine to create an optical feedback loop. Symptoms can include: poor range, intermittent operation or no operation.

each wire into the appropriate hole on the main system units' screwless connector (Figure 2), and snap the locking tab down. To help you, the connector plug is keyed. Insert the smooth side of the connector plug into the smooth side of the socket. Don't force the scalloped side of the connector plug into the smooth side of the socket.

6. Secure the MS120 by tightening the hex nut. DO NOT OVER-TIGHTEN.

### Tools Required

- 1/8" Standard Slotted Screwdriver
- Adjustable wrench or pliers
- Wire Stripper

**NOTE:** Do not install the MS120 next to a light dimmer

## OPERATION

Operation of the MS120 is straightforward. Simply aim your hand-held remote at the MS120. Your IR command is instantly repeated to your A/V equipment.

## INSTALLATION

If you are installing the MS120 into an existing wall, take time to consider any possible obstructions which may be hidden inside the wall, such as wood or metal studs; electrical, telephone or other types of wiring; plumbing; AC or heating conduits; old wall safes; etc.

1. Determine a mounting location for the MS120. Select a location where you will have access to the rear of the MS120 after it is installed. This will allow you to securely tighten the MS120 to the mounting surface using the supplied hardware.
2. Drill a 1/2" hole where the MS120 will be mounted.
3. Run the MS120's IR cable. Label the cable for future reference. The MS120 is supplied with 10' of pre-stripped IR cable. The IR cable may be shortened or lengthened as needed. If you want to make the MS120's cable shorter, use a pair of wire cutters to cut the cable to the desired length. The IR cable may be lengthened by splicing it to a recommended IR cable (See Installation Considerations—Type of Cable). You may splice the MS120 cable to another cable by soldering or crimping the connections.
4. Connect the MS120 cable to the main system unit. Strip 1/4" of insulation from the end of each wire. Tightly twist the end of each wire until there are no frayed ends. Insert the end of



## INTRODUCTION

The MS120 is a flush-mount IR sensor designed for use with the Niles infrared extender systems.

Installed in a remote room location, the MS120 receives the IR commands transmitted from your existing hand-held remotes in that room. The commands are carried via a CAT-5 cable to your A/V equipment in another room, and instantly “repeated”.

The MS120 is compatible with all current Niles infrared systems. It may be used along with, or as an alternative to, the Niles TS120, WS120, MS120, MS220 and CS120 sensors or the IntelliPad®.

The MS120 is just one part of the three building blocks necessary to complete a Niles IR repeating system:

- *IR Main System Unit—Models MSU140, MSU250, MSU480 and MSU440Z.*
- *IR Sensors/Keypads—Models WS120, TS120, MS120, MS220, CS120, and the IntelliPad.*
- *IR Flashers—Models MF1, MF1VF, MF2, MF2VF and the IRB1.*

An IR sensor expansion hub, Model IRH610, is available to provide additional sensor inputs to your system.

**IMPORTANT:** Refer installation to a professional custom installer if you are unfamiliar with any of the following procedures.

## FEATURES & BENEFITS

The MS120 offers a number of improvements over other miniature IR sensors.

- *Wideband High-Fidelity Design enables operation with virtually any brand of equipment*
- *Patent Pending Universal Noise Suppression Design enables operation in virtually any environment: near plasma and LCD displays, compact fluorescent lights, and indirect sunlight*
- *Excellent IR receiving range — 20' to 35' of remote control range (depending upon the strength of your handheld remote)*
- *Small size of only 1/2" diameter by 2-7/8" long—fits almost anywhere*
- *10' connecting cable included*
- *Printed circuit board design uses surface mount technology, assuring high reliability*
- *Ideal for both home and commercial installations*
- *Two year parts and labor limited warranty*

## INSTALLATION CONSIDERATIONS

### Type of Cable

The MS120 connects to the Niles infrared main systems unit or IRH610 sensor expansion hub with an individual home run of CAT-5 cable. When running wires inside walls, most states and municipalities in the U.S. specify that you must use a special type of wire. Usually, the requirement is that the wire has a specific “CL” fire rating, such as “CL-2” or “CL-3”. Consult your Niles dealer, building contractor, or local building and inspection department if unsure about which type of wire is best for your application.

### MS120 Mounting Location

The MS120 is ideal for use in applications when tabletop, ceiling, or wall-mounting is undesirable. Its small size and unobtrusive appearance makes it ideal for installation in obscure, hidden locations, in cabinet facings, or in the sensor knockout built into Niles in-wall loudspeakers. Installing the MS120 close to the primary location of the user will ensure best performance.

The MS120 is designed to flush-mount almost anywhere. Convenient mounting locations for the MS120 are:

- In a cabinet door
- In a wall, or wall-plate
- Behind a speaker grille.\*

**NOTE:** Some types of speaker grilles will reduce the IR pickup range of the MS120. If unsure, test the pickup range before permanently installing the MS120 behind the speaker grille.

### Receiving Range and Pickup Angle

The receiving range of the MS120 will vary according to the IR output strength of the remote control being used. Remote strength varies among brands depending on the number and size of batteries used, and how many IR emitters the remote has. For example, remotes that operate on two small AAA batteries and have only one IR emitter are generally not as strong as remotes that use the larger AA size batteries and have two emitters. Tests with various manufacturers’ remote controls have shown that the operating range can vary from a minimum of 20’ to a maximum of about 35’.

Infrared signals travel essentially line-of-sight. They will not pass through or around solid objects. Do not rely on an IR signal being able to “bounce” off a wall or object to the MS120.

The IR pickup angle of the MS120 is 30° off-axis (horizontal and vertical) at 25’.

### Avoiding Electrical Interference

Avoid locating the MS120 near any potential sources of electrical or optical noise, such as light dimmers, low-voltage lights, and neon lights.

### Do not install the MS120 into electrical boxes with 110 volt devices

Some states or municipalities allow devices such as the MS120 to be installed into the same electrical box as 110 volt devices, provided a “low-voltage partition” is used between the devices.

We do not recommend this. The cable connected to the MS120 can act as an “antenna” for electrical noise. Locating the MS120 cable too close to a light dimmer or switch may interfere with the MS120. If you must locate the MS120 near electrical devices, install it in a separate metal electrical box, ground the box to the electrical system ground, and route the MS120 cable several feet away from all electrical wiring.

### Avoiding Optical Feedback

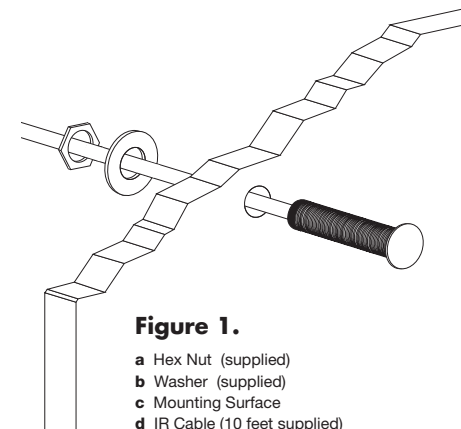
If installing the MS120 in the same room as an IR flasher, it is possible for the flasher’s IR output to be picked-up by the MS120. This effect, known as an optical feedback loop, can cause erratic operation. Optical feedback is similar to acoustical feedback: the howling or whistling sound heard in a P.A. system when the microphone is too close to the speaker.

To avoid optical feedback:

1. Re-position the flasher(s) and/or the sensor.
2. Use Niles MF1 or MF2 flashers and cover them with the supplied IR blockers.

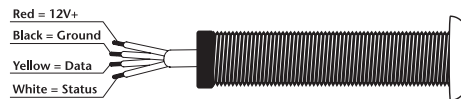
### Using the MS120 with a Niles MultiZone Keypad with an IR-Sensor Connection

The MS120 is fully compatible with any Niles MultiZone Keypad with an IR-Sensor connection, follow the wiring instructions in **Figure 2**. For specific information see your Niles MultiZone Keypad manual.

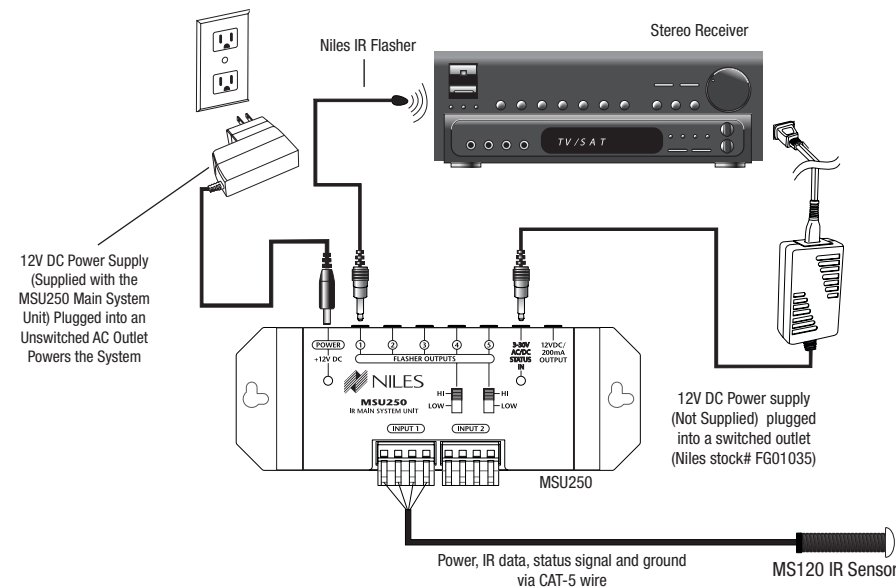


**Figure 1.**

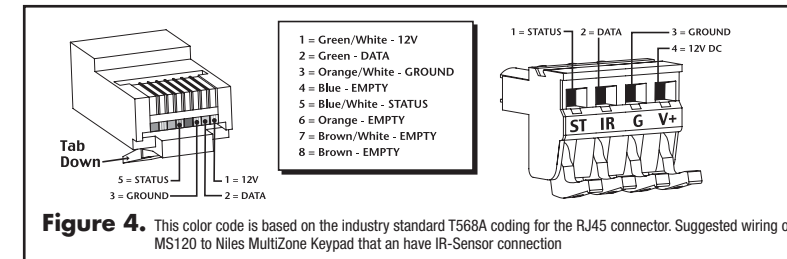
- a Hex Nut (supplied)
- b Washer (supplied)
- c Mounting Surface
- d IR Cable (10 feet supplied)
- e MS120 Miniature IR Sensor (supplied)
- f MS120 Lens Bezel (supplied)



**Figure 2.** Wiring legend



**Figure 3.** Wiring Diagram (Typical installation with an MSU250 Main System Unit)



**Figure 4.** This color code is based on the industry standard T568A coding for the RJ45 connector. Suggested wiring of MS120 to Niles MultiZone Keypad that have IR-Sensor connection